



MASTER LED Lamps

MASTER LED 8W 830 MR16 36D Dim AU

Delivering a warm, halogen/incandescent-like accent beam, MASTER LED lamp is an ideal retrofit solution for spot and general lighting applications in the hospitality industry. It is particularly suited to public areas such as receptions, lobbies, corridors, stairwells and washrooms, where the light is on all the time. MASTER LED delivers huge energy savings and minimizes maintenance cost without any compromise on brightness, enabling hospitality owners to achieve a fast return on their investment. These LED lamps are compatible with most fixtures and designed as a retrofit replacement alternative for halogen lamps or incandescent lamps.

Product data

• General Information

Cap-Base	GU5.3 [GU5.3]
Bulb Shape	MR16 [2inch/50mm]
Nominal Lifetime (Nom)	40000 h
Switching Cycle	50000X
Technical Type	8-50W

• Light Technical

Color Code	830 [CCT of 3000K]
Beam Angle (Nom)	36 °
Light Distribution	Medium beam 36°
Luminous Flux (Nom)	660 lm
Luminous Flux (Rated) (Nom)	660 lm
Luminous Intensity (Nom)	1700 cd
Color Designation	White (WH)
Rated Beam Angle	36 °
Correlated Color Temperature (Nom)	3000 K
Luminous Efficacy (rated) (Nom)	78 lm/W
Color Consistency	6 steps
Color Rendering Index (Nom)	80
LLMF At End Of Nominal Lifetime (Nom)	70 %
Luminous Flux In 90° Cone (Rated)	621 lm

• Operating and Electrical

Input Frequency	50 to 60 Hz
-----------------	-------------

Power (Rated) (Nom)	8 W
Lamp Current (Nom)	900 mA
Wattage Equivalent	50 W
Starting Time (Max)	0.5 s
Warm Up Time To 60% Light (Nom)	instant full light
Power Factor (Nom)	0.7
Voltage (Nom)	12 V

• Temperature

T-Case Maximum (Nom)	105 °C
----------------------	--------

• Controls and Dimming

Dimmable	Yes
----------	-----

• Approval and Application

Suitable For Accent Lighting	Yes
Energy Efficiency Label (EEL)	A+
Energy Consumption kWh/1000 h	9 kWh

• Product Data

Full product code	871869649017400
Order product name	MASTER LED 8W 830 MR16 36D Dim AU
EAN/UPC - Product	8718696490174
Order code	929001150219
Numerator - Quantity Per Pack	1

PHILIPS

MASTER LED Lamps

Numerator - Packs 10
per outer box

Material Nr. (12NC) 929001150219
Net Weight (Piece) 0.045 kg

Dimensional drawing

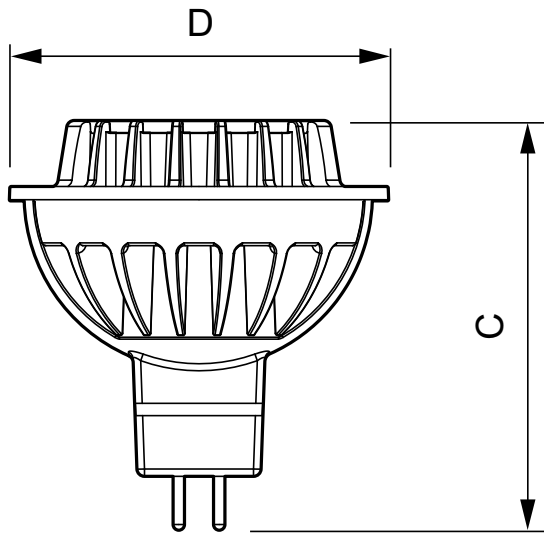

8-50 W GU5.3 MR16

LED D 8-50W 830 MR16 36D

Product	D	C
MASTER LED 8W 830 MR16 36D Dim AU	51 mm	55 mm

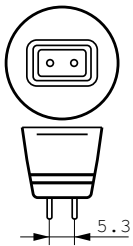

Photometric data

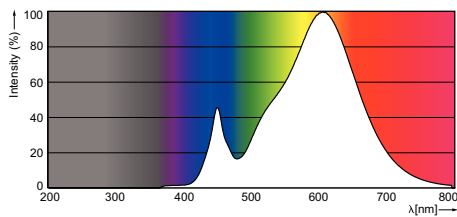

© 2016 Philips Lighting Holding B.V.
All rights reserved.

Specifications are subject to change without notice. Trademarks are the property of Koninklijke Philips N.V. (Royal Philips) or their respective owners.

www.philips.com/lighting

2016, March 11
data subject to change